

## 2.1 General assembly

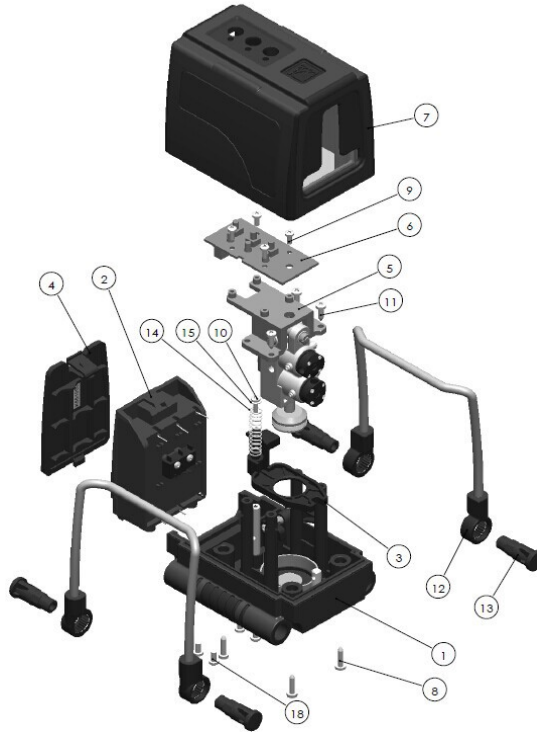

NO.	NAME	Figure NO.	Material	Quantity to order
1	892 Base assembly	LA-10-892-100		
2	892 Battery box assembly	LA-10-892-500		
3	892 The locking ring	LA-10-892-001	ABS	
4	892 Battery cover	LA-10-892-002	ABS	
5	892 pendulum assembly	LA-10-892-300		
6	892 Main board	LA-10-892-003	PCBA	
7	892 Shell assembly	LA-10-892-200		
8	GB_CROSS_SCREWS_TYPE128 ST2.9X13 H F-N		SUS304	
9	GB_CROSS_SCREWS_TYPE1 M2.5X6-6 H type-N		SUS304	
10	GB_CROSS_SCREWS_TYPE1 M2.5X6-6 H type-N		SUS304	

11	GB_CROSS_SCREWS_TYPE128 ST2.9X9.5 H F-N		SUS304	
12	892 Metal feet assembly	LA-10-892-400		
13	892 The center shaft	LA-10-892-004	POM	
14	892 spring	LA-10-892-005	65Mn	
15	GB_FASTENER_WASHER_PWNA 3		Q235,	
16	892 Enameled copper wire	LA-10-892-006	H62	
17	892 Alarm ring connection line	LA-10-892-007		
18	GB_CROSS_SCREWS_TYPE1 M3X6-6 H type-N			
19	892 main panel labeling			
20	AA Battery			

## 2.2 Base assembly

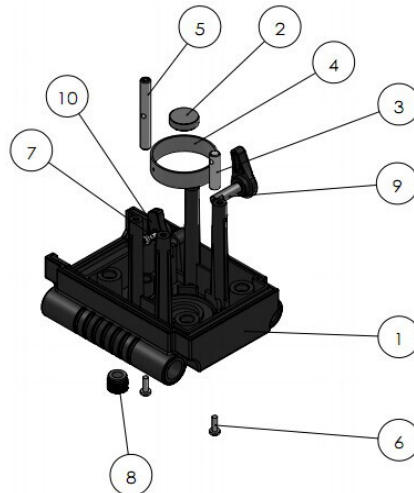

NO.	NAME	Figure NO.	Material	Quantity to order
1	892 Base	LA-10-892-101	ABS+TPR	
2	892 Magnet	LA-10-892-102	NdFeB Rare Earth magnet	
3	892 Guide pillar 1	LA-10-892-103	Q235	

4	892 Alarm ring	LA-10-892-104	6063	
5	892 Guide pillar 2	LA-10-892-105	Q235	
6	GB_CROSS_SCREWS_TYPE1 M2.5X8-8 H type-N		SUS304	
7	GB_CROSS_SCREWS_TYPE1 M2.5X6-6 H type-N		SUS304	
8	892 Base insert	LA-10-892-106	HPb59-1	
9	892 Switch to pump	LA-10-892-108	ABS	
10	892 Cam switch	LA-10-892-109	POM	

### 2.3 Shell assembly

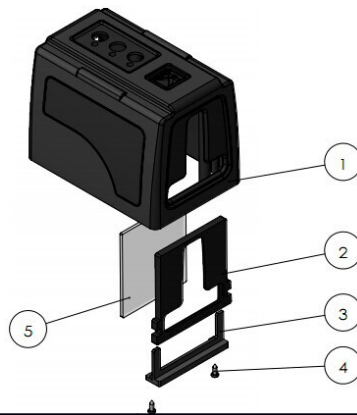

NO.	NAME	Figure NO.	Material	Quantity to order
1	892 Shell	LA-10-892-204	ABS+TPR	
2	892 Rubber window	LA-10-892-201	TPE	
3	892 Window frame	LA-10-892-203	ABS	
4	GB_CROSS_SCREWS_TYPE128 ST2.2X6.5 H C-N		SUS304	
5	892 Window pane	LA-10-892-202	K9	

## 2.4. Pendulum assembly

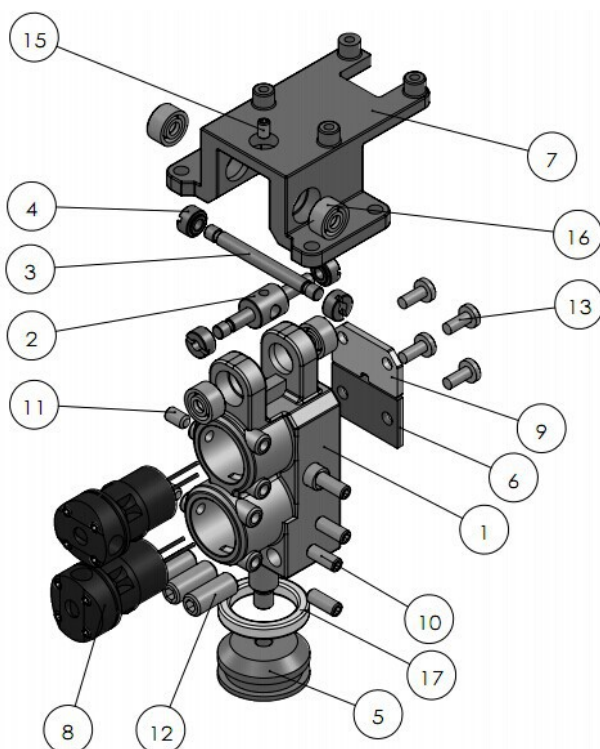

NO.	NAME	Figure NO.	Material	Quantity to order
1	892 pendulum mass	LA-10-892-301	7# Zn alloy	
2	892 center shaft 1	LA-10-892-303	SUS304	
3	892 center shaft 2	LA-10-892-304	SUS304	
4	892 Pressure ring	LA-10-892-305	HPb59-1	
5	892 pendulum	LA-10-892-306	T2	
6	892 The adapter plate	LA-10-892-307	PCBA	
7	892 Roof	LA-10-892-302	7# Zn alloy	
8	892 line laser	LA-10-892-		

		308		
9	892 The counterweight block	LA-10-892-309	Q235	
10	GB_FASTENER_SCREWS_HSFP M3X8-N		45# ,12.9 级	
11	GB_FASTENER_SCREWS_HSFP M3X5-N		45# ,12.9 级	
12	GB_FASTENER_SCREWS_HSFP M5X10-N		SUS304	
13	GB_CROSS_SCREWS_TYPE1 M2.5X6-6 H type-N		SUS304	
15	GB_FASTENER_SCREWS_HSFP M2.5X4-N		45# ,12.9 级	
16	bearing 693ZZ			
17	892 Conductive rubber ring	LA-10-892-310	Conductive rubber	

## 2.5 .Metal feet assembly

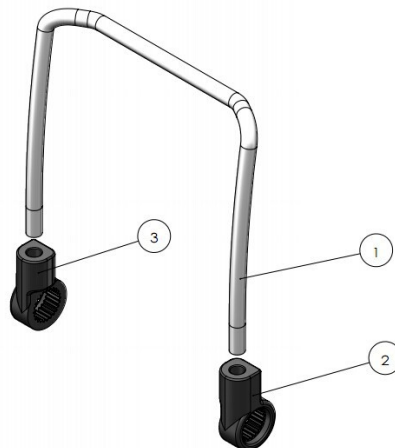

NO.	NAME	Figure NO.	Material	Quantity to order
1	892 Metal feet	LA-10-892-401	SUS304	
2	892 Metal feet left	LA-10-892-402	PA66	

3	892 Metal feet right	LA-10-892-403	PA66	
---	----------------------	---------------	------	--

## 2.6. Battery box assembly

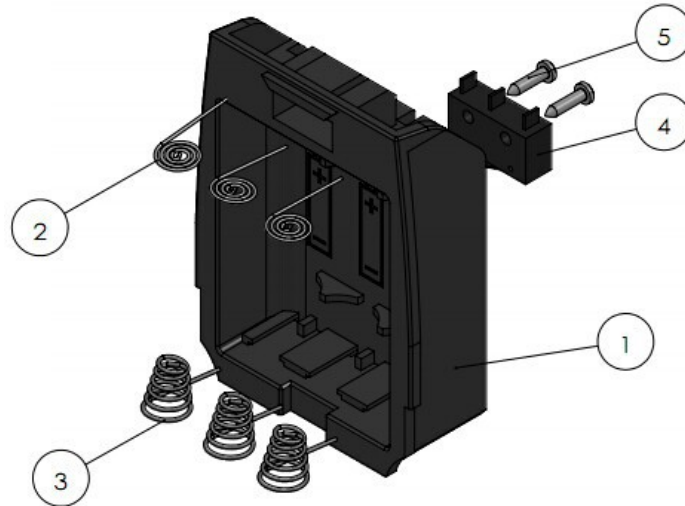

NO	NAME	Figure NO.	Material	Quantity to order
1	892 The battery box	LA-10-892-501	ABS	
2	892 Positive terminal	LA-10-892-502	65Mn	
3	892 spring terminal	LA-10-892-503	65Mn	
4	892 travel switches	LA-10-892-504		
5	GB_CROSS_SCREWS_TYPE128 ST2.2X9.5 H C-N		SUS304	
6	892 Battery pole line	LA-10-892-505		
7	892 Power cord 1	LA-10-892-506		
8	892 Power cord 2	LA-10-892-507		